

# KOMATSU®

## D65EX-16 D65PX-16 D65WX-16

### NET HORSEPOWER

153 kW **205 HP** @ 1950 rpm

### OPERATING WEIGHT

D65EX-16: 19950 kg **43,980 lb**

D65PX-16: 21300 kg **46,960 lb**

D65WX-16: 20670 kg **45,570 lb**

**D**  
**65**

CRAWLER DOZER



Photos may include optional equipment.

# WALK-AROUND

## **OUTSTANDING PRODUCTIVITY & FUEL ECONOMY**

**Innovative SIGMADOZER** reduces digging resistance and smoothly rolls material up for increased blade loads.

Blade capacity: 5.6 m<sup>3</sup> **7.3 yd<sup>3</sup>** (for EX)

5.9 m<sup>3</sup> **7.7 yd<sup>3</sup>** (for WX)

**Automatic transmission with lockup torque converter** improves fuel consumption.

**SAA6D114E-3 turbocharged and aftercooled diesel engine** provides a net output of 153 kW **205 HP** with excellent fuel economy. This engine is EPA Tier 3 and EU Stage 3A emissions certified.

**Hydraulic Driven Radiator Cooling Fan** controlled automatically, reduces fuel consumption and operating noise levels.

**Gull-wing** engine side doors open wide for easy and efficient servicing.

**Blade tilt lines** completely protected.

**Parallel Link Undercarriage System (PLUS)** provides up to double the wear life and lower repair & maintenance costs with new rotating bushings and other key enhancements.

**Power Angle Tilt (PAT) Dozer** with manually adjustable blade pitch expands productivity in a variety of applications.



KOMTRAX equipped machines can send location, SMR and operation maps to a secure website utilizing wireless technology. Machines also relay error codes, cautions, maintenance items, fuel levels, and much more.

## **Complete operator control**

- Palm Command Control System (PCCS)
  - Electronic PCCS travel control
  - Hydraulic PCCS blade/ripper control
- Fuel control dial
- Automatic/manual shift selectable mode
- Shift pattern preset function
- ECMV controlled transmission

## **Increased track length for EX/WX**

ensures outstanding grading ability and stability.

## **Extra-low machine profile**

provides excellent machine balance and low center of gravity.



***New integrated ROPS cab includes:***

- Large quiet operator environment
- Comfortable ride with new cab damper
- Excellent visibility without external ROPS posts
- Automatic high capacity air conditioning
- Pressurized cab
- Adjustable armrest and suspension seat
- Cab meets OSHA/MSHA ROPS and FOPS Level 2 standards

***Hydrostatic Steering System (HSS)***

provides smooth, quick, and powerful control in various ground conditions.

**NET HORSPOWER**

153 kW **205 HP** @ 1950 rpm

**OPERATING WEIGHT**

D65EX-16:	19950 kg	<b>43,980 lb</b>
D65PX-16:	21300 kg	<b>46,960 lb</b>
D65WX-16:	20670 kg	<b>45,570 lb</b>

**BLADE CAPACITY**

<b>SIGMADOZER:</b>		
D65EX-16:	5.61 m <sup>3</sup>	<b>7.34 yd<sup>3</sup></b>
D65WX-16:	5.90 m <sup>3</sup>	<b>7.72 yd<sup>3</sup></b>
<b>Straight Tilt Dozer:</b>		
D65EX-16:	3.89 m <sup>3</sup>	<b>5.09 yd<sup>3</sup></b>
D65PX-16:	3.69 m <sup>3</sup>	<b>4.83 yd<sup>3</sup></b>
<b>Power Angle Tilt Dozer:</b>		
D65EX-16:	4.25 m <sup>3</sup>	<b>5.56 yd<sup>3</sup></b>
D65PX-16:	4.42 m <sup>3</sup>	<b>5.78 yd<sup>3</sup></b>
D65WX-16:	4.42 m <sup>3</sup>	<b>5.78 yd<sup>3</sup></b>

***Rear hydraulics***

- Standard feature
- Increased versatility

***Large TFT LCD monitor***

- Easy-to-read and use large 7" multi-color monitor
- Choice of 10 languages for local customization

TFT : Thin Film Transistor  
LCD : Liquid Crystal Display

***Self-adjusting idler support***

provides constant and even idler tension, reducing vibrations and increasing undercarriage life.

***High-rigidity, simple hull frame***

and monocoque track frame with pivot shaft for greater reliability.

***Modular power train*** for increased serviceability and durability.

***Wet, multiple-disc brakes***

for adjustment-free operation.

# PRODUCTIVITY & ECOLOGY FEATURES

## Engine



**ecology & economy - technology 3**

Komatsu's new "ecot3" engines are designed to deliver optimum performance under the toughest of conditions, while meeting the latest environmental regulations. This engine is EPA Tier 3 and EU Stage 3A emissions certified; "ecot3" - ecology and economy combine with Komatsu technology to create a high performance engine without sacrificing power or productivity.

The Komatsu SAA6D114E-3 engine delivers a net output of 153 kW **205 HP** at 1950 rpm. The fuel-efficient Komatsu

engine, together with the heavy machine weight, make the D65EX/PX/WX superior crawler dozers in both ripping and dozing operations. The engine features direct fuel injection, turbocharger, and an air-to-air aftercooler to maximize power and fuel efficiency.

To minimize noise and vibration, the engine is mounted to the main frame with rubber cushions.



## Fuel Efficient

The new D65 achieves both high levels of productivity and fuel economy through the use of the SIGMADOZER and an automatic transmission with lockup torque converter.

**SIGMADOZER**



Automatic transmission with lock up torque converter



**PRODUCTION:**  
**15% increase**

**FUEL CONSUMPTION:**  
**10% decrease**

**FUEL EFFICIENCY:**  
**25% increase**

*(compared with a conventional Semi-U blade model)*

## Outstanding Productivity

### SIGMADOZER – The Next Generation Blade

Based on a completely new digging theory, SIGMADOZER dramatically improves dozing performance and increases productivity. A new frontal design concept adopted for digging and rolling material up at the center of the blade increases soil holding capacity while simultaneously reducing side spillage. It also reduces digging resistance

producing a smoother flow of earth, enabling the dozing of larger quantities of soil with less power.

**Production increased by 15%**

*(compared with a conventional Semi-U blade model)*



**SIGMADOZER (D65-16)**



**Semi-U blade (D65-15)**

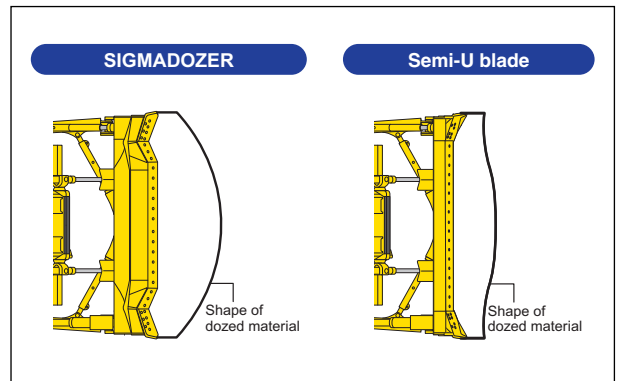

## Outstanding Fuel Economy

### Automatic Transmission With Lockup Torque Converter

A sharp reduction in fuel consumption and greater power train efficiency are achieved by the new automatic transmission and lockup torque converter. The automatic transmission selects the optimal gear range depending on the working conditions and load placed on the machine. This means the machine is always operating at maximum efficiency.

*Fuel consumption decreased by **10%**  
(compared with a conventional model)*

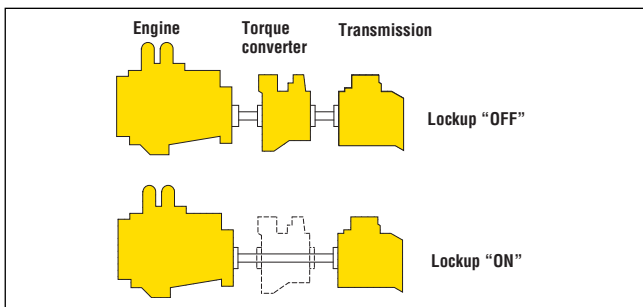

The lockup mechanism of the torque converter is automatically actuated to transfer engine power directly to the transmission in travelling and usual dozing speed ranges. Locking up the torque converter reduces loss of power by 10%. Because the electronically controlled engine is extremely efficient, a decrease in fuel consumption is realized while also maintaining machine power.

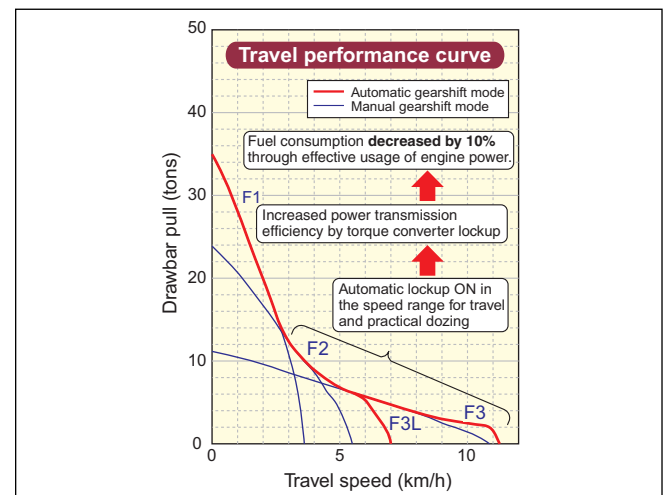

## Other Ecology Features

### Selectable Working Mode

Working mode E is for general dozing applications with adequate speed and power while reducing fuel consumption and CO<sub>2</sub>. Working mode P is aimed at powerful operation and maximum production. The working mode is easily switched on the monitor panel, depending on the work at hand.

- **E mode (Economy mode)**

With E mode, the engine outputs enough power for most general dozing applications without delivering unnecessary power. This mode allows for energy saving operation and is suitable for work on ground where the machine may experience shoe slip or applications not requiring large power such as downhill dozing, leveling and light-load work.

- **P mode (Power mode)**

With P mode, the engine outputs its full power, allowing the machine to perform large production, heavy-load, or uphill work.

### Hydraulic Driven Radiator Cooling Fan

The engine cooling fan rotation speed is electronically controlled. The fan rotation speed depends on engine coolant and hydraulic oil temperatures; the higher the temperature the higher the fan speed. This system increases fuel efficiency, reduces the operating noise levels and requires less horsepower than belt driven fans.



# COMPLETE OPERATOR CONTROL

## Human-Machine Interface

### Palm Command Control System (PCCS) Travel Joystick

Palm command travel joystick provides the operator with a relaxed posture and superb fine control. Transmission shifting is simplified with thumb push buttons.

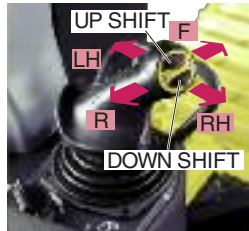

### Palm Command Proportional Pressure Control (PPC) Blade Control Joystick

Blade control joystick uses the PPC valve and joystick, similar to the travel control joystick. PPC control combined with the highly reliable Komatsu hydraulic system enables superb fine control.



## Power Train Electronic Control System

### Automatic/Manual Shift Selectable Mode

Automatic or manual shift modes can be selected with ease to suit the work at hand by simply pressing the switch on the multi-monitor (selection at neutral).

- **Automatic shift mode**

Select for all general dozing. When a load is applied, the transmission automatically shifts down, and when the load is off, it automatically shifts up to a set maximum gear speed. This mode economizes both fuel and production further when the torque converter lockup mechanism is actuated according to load, providing a one to one drive.

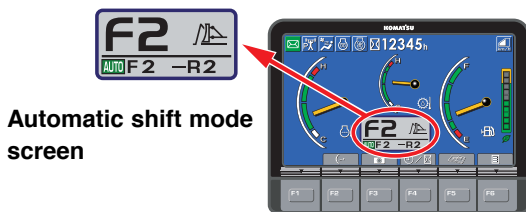

- **Manual shift mode**

Select for dozing and ripping rough ground. When loaded, the transmission automatically shifts down, but does not shift up when the load is off.



### Shift Pattern Preset Function

When the shift pattern is set to either <F1-R2>, <F2-R1>, <F2-R2>, <F2-R3L> or <F3L-R3L> in the automatic mode, the transmission automatically shifts to the preset gear when the travel control joystick is set to Forward or Reverse position, reducing work cycle time and operator effort. Shift patterns <F2-R3L> and <F3L-R3L> are newly added for high speed leveling operation.

	Automatic gearshift mode	Manual gearshift mode
	<b>F1-R1 MODE</b> Press DOWN switch ↓ Press UP switch	<b>F1-R1 MODE</b> Press DOWN switch ↓ Press UP switch
	<b>F1-R2 MODE</b> Press DOWN switch ↓ Press UP switch	<b>F1-R2 MODE</b> Press DOWN switch ↓ Press UP switch
	<b>F2-R1 MODE</b> Press DOWN switch ↓ Press UP switch	<b>F2-R1 MODE</b> Press DOWN switch ↓ Press UP switch
	<b>F2-R2 MODE</b> Press DOWN switch ↓ Press UP switch	<b>F2-R2 MODE</b> Press DOWN switch ↓ Press UP switch
	<b>F2-R3L MODE</b> Press DOWN switch ↓ Press UP switch	<b>F2-R3L MODE</b> Press DOWN switch ↓ Press UP switch
	<b>F3L-R3L MODE</b>	<b>F2-R3 MODE</b>

### Electronic Controlled Modulation Valve (ECMV) Transmission

A controller automatically adjusts each clutch engagement depending on travel conditions, providing smooth shockless clutch engagement, improved component life and operator ride comfort.

### Hydrostatic Steering System (HSS)—Smooth, Powerful Turning

The engine power is transmitted to both tracks without power interruption on the inside track for smooth, powerful turns. Counter-rotation is available for minimum turning radius, enhancing maneuverability.

# WORKING ENVIRONMENT

### Newly Integrated ROPS Cab

A newly designed cab; wider, deeper and taller, is integrated with the ROPS. High rigidity and superb sealing performance sharply reduce noise and vibration for the operator and minimize dust entering the cab. The standard air-ride seat positions the operator 3" higher and 4" closer to the blade. The taller and narrower battery box and tanks plus larger glass area also improve visibility of the blade, sides, and rear of the machine. Cab meets OSHA/MSHA ROPS and FOPS Level 2 standards.



### Comfortable Ride with Cab Damper Mounting

The D65's cab mount uses a cab damper which provides excellent shock and vibration absorption capacity. The long stroke cab damper mounts soften shocks and vibration while traveling over adverse conditions, which conventional rubber mounting systems are unable to match. The cab damper spring isolates the cab from the machine body, suppressing vibration and providing a quiet, comfortable operating environment.

### Power Angle Tilt (PAT) Dozer

A Power Angle Tilt dozer blade with highly durable box-structure frame is available for the EX, WX and PX machines. The hydraulic blade tilt and angling functions and manually adjustable blade pitch expand versatility and productivity in a variety of applications. This PAT dozer assembly is tested to the same stringent test standards as Komatsu's outside mounted blades.



Photos may include optional equipment.

### Large Multi-Lingual LCD Color Monitor

A large user-friendly color monitor enables accurate and smooth work. Excellent screen visibility is achieved by the use of a TFT liquid crystal display that can easily be read at various angles and lighting conditions. Simple and easy to operate switches. Function keys facilitate multi-function operations. Data can be displayed in 10 languages for local customization.

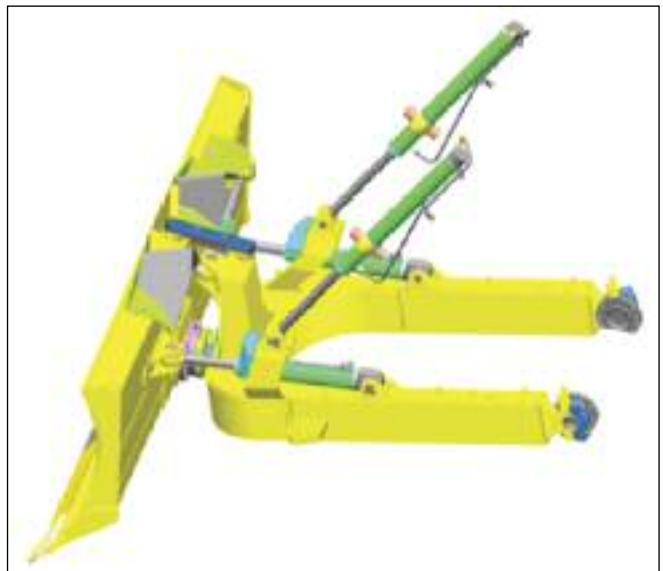
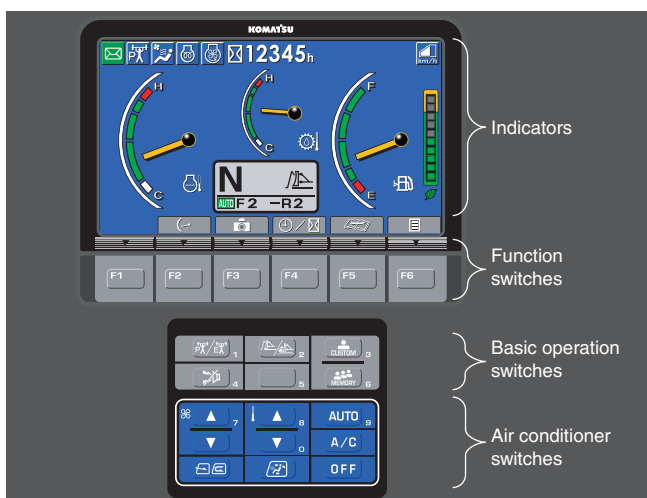

# MAINTENANCE AND RELIABILITY FEATURES

## Planned Maintenance

### Multi-monitor with Troubleshooting Function to Help Prevent Critical Machine Troubles

Various meters, gauges and warning functions are centrally arranged on the multi-monitor. The monitor simplifies start-up inspection and promptly warns the operator with a lamp and buzzer if any abnormalities should occur. In addition, countermeasures are indicated in 4 levels to help prevent major problems. Replacement times for oil and filters are also indicated.



### Gull-wing Engine Side Covers

The engine side covers are gull-wing type with a gas spring, and the opening angle of the cover is further increased to facilitate engine maintenance and filter replacement.

## Low Maintenance Costs

### Parallel Link Undercarriage System (PLUS)

Komatsu's innovative Parallel Link Undercarriage System features a rotary bushing that demonstrates high durability in any working conditions. Allowing the bushing to rotate virtually eliminates bushing wear, resulting in doubled service life of the undercarriage when compared with the conventional undercarriage. In addition, wear limits of the link and carrier roller are increased to balance with the extended service life of the bushing.

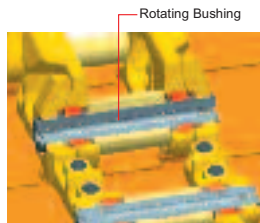

### Reliable Simple Hull Frame

Simple hull structure main frame design increases durability and reduces stress concentration at critical areas. The track frame has a large cross section and utilizes pivot shaft mounting for greater reliability.

## KOMTRAX®

### Information is Key

KOMTRAX is Komatsu's remote equipment and fleet monitoring system. Wireless technology and a secure Web-based application gives you the information you need to make the best possible operation and management decisions, from location, actual hours worked, and fuel

### Oil Pressure Check Ports

Pressure check ports for power train components are centralized to promote quick and simple diagnosis.

### Easy Radiator Cleaning with Hydraulic Driven Fan

The radiator can be cleaned by utilization of the reversible, hydraulically driven cooling fan. The fan can be reversed from inside the cab by simply activating a switch.



### Wide Core Cooling Package

In addition to improved sealing, a new wide core cooling system is standard. Radiator, oil cooler and charge air cooler use large square-wave fins spaced at 6 fins per inch. This allows more material to pass through and reduces maintenance.

### Self-adjusting Idler Support

Self-adjusting idler support applies a constant spring force to the wear plate of the idler guide to eliminate the play of the idler. This results in reduced noise and vibration as well as extended service life of the wear plate.

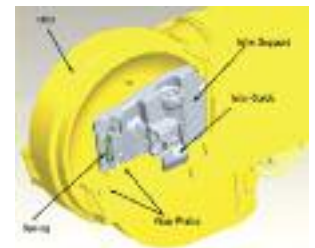

### Robust Guarding Package

Komatsu offers a full guarding package that is designed using extensive customer feedback to protect your investment. This lowers operating costs by minimizing machine damage.



consumption to maintenance monitoring, abnormality codes, and load frequency, in simple to read and understand reports. Real time information for better decisions and better returns.





## SPECIFICATIONS



### FINAL DRIVES

Double-reduction final drive of spur and planetary gear sets to increase tractive effort and reduce gear tooth stresses for long final drive life. Segmented sprocket teeth are bolt-on for easy replacement.



### SERVICE REFILL CAPACITIES

Fuel tank	415 ltr	<b>109.6 U.S. gal</b>
Coolant	36 ltr	<b>9.5 U.S. gal</b>
Engine	28 ltr	<b>7.4 U.S. gal</b>
Torque converter, transmission, bevel gear, and steering system	48 ltr	<b>12.7 U.S. gal</b>
Final drive (each side)		
D65EX-16	24 ltr	<b>6.3 U.S. gal</b>
D65EX-16 with PAT	27 ltr	<b>7.1 U.S. gal</b>
D65PX-16	27 ltr	<b>7.1 U.S. gal</b>
D65WX-16	27 ltr	<b>7.1 U.S. gal</b>



### HYDRAULIC SYSTEM

Closed-center load sensing system (CLSS) designed for precise and responsive control, and for efficient simultaneous operation.

Hydraulic control units:

All spool valves externally mounted beside the hydraulic tank.

Piston type hydraulic pump with capacity (discharge flow) of 248 ltr/min **65.5 U.S. gal/min** at rated engine rpm.

Relief valve setting . . . . . 27.9 MPa 285 kg/cm<sup>2</sup> **4,050 psi**

Control valves:

Spool control valves for SIGMADOZER or straight tilt dozer

    Positions: Blade lift . . . . . Raise, hold, lower, and float

    Blade tilt . . . . . Right, hold, and left

    Rear attachment . . . . . Raise, hold, and lower

Spool control valves for Power Angle Tilt dozer

    Positions: Blade lift . . . . . Raise, hold, lower, and float

    Blade tilt . . . . . Right, hold, and left

    Blade angle . . . . . Right, hold, and left

    Rear attachment . . . . . Raise, hold, and lower

Hydraulic cylinders . . . . . Double-acting, piston

	Number of cylinders	Bore	
		SIGMADOZER Straight Tilt Dozer	Power Angle Power Tilt Dozer
Blade lift	2	85 mm <b>3.3"</b>	90 mm <b>3.5"</b>
Blade tilt	1	125 mm <b>4.9"</b>	130 mm <b>5.1"</b>
Blade angle	2	N/A	110 mm <b>4.3"</b>
Ripper lift	1	125 mm <b>4.9"</b>	125 mm <b>4.9"</b>
Pitch angle	1	39° - 53°	52° - 58°

Hydraulic oil capacity (refill): . . . . . 55 ltr **14.5 U.S. gal**

Ripper equipment (additional volume):

    Multi-shank ripper . . . . . 7 ltr **1.8 U.S. gal**



### DOZER EQUIPMENT

Blade capacities are based on the SAE recommended practice J1265.

Use of high tensile strength steel in moldboard for strengthened blade construction.

	Overall Length With Dozer mm ft.in	Blade Capacity m <sup>3</sup> yd <sup>3</sup>	Blade Width x Height mm ft.in	Max. Lift Above Ground mm ft.in	Max. Drop Below Ground mm ft.in	Max. Tilt Adjustment mm ft.in	Weight	Ground Pressure* kPa kg/cm <sup>2</sup> psi
							Dozer equipment kg lb	
<b>D65EX-16</b> SIGMADOZER	5490 <b>18'0"</b>	5.61 <b>7.34</b>	3410 x 1425 <b>11'2" x 4'8"</b>	1135 <b>3'9"</b>	500 <b>1'8"</b>	870 <b>2'10"</b>	2390 <b>5,260</b>	58.8/0.60/ <b>8.53</b>
<b>D65EX-16</b> Straight Tilt Dozer	5330 <b>17'6"</b>	3.89 <b>5.09</b>	3415 x 1225 <b>11'2" x 4'0"</b>	1105 <b>3'8"</b>	430 <b>1'5"</b>	870 <b>2'10"</b>	2060 <b>4,540</b>	56.6/0.58/ <b>8.22</b>
<b>D65EX-16</b> Power Angle Tilt Dozer	5790 <b>19'0"</b>	4.25 <b>5.56</b>	3870 x 1235 <b>12'8" x 4'1"</b>	1170 <b>3'10"</b>	695 <b>2'3"</b>	500 <b>1'8"</b>	2960 <b>6,530</b>	62.8/0.64/ <b>9.11</b>
<b>D65PX-16</b> Straight Tilt Dozer	5680 <b>18'8"</b>	3.69 <b>4.83</b>	3970 x 1100 <b>13'0" x 3'7"</b>	1130 <b>3'8"</b>	535 <b>1'9"</b>	890 <b>2'11"</b>	2100 <b>4,630</b>	34.8/0.36/ <b>5.06</b>
<b>D65PX-16</b> Power Angle Tilt Dozer	5790 <b>19'0"</b>	4.42 <b>5.78</b>	4010 x 1235 <b>13'2" x 4'1"</b>	1170 <b>3'10"</b>	695 <b>2'3"</b>	520 <b>1'8"</b>	2990 <b>6,590</b>	43.7/0.45/ <b>6.34</b>
<b>D65WX-16</b> SIGMADOZER	5500 <b>18'1"</b>	5.90 <b>7.72</b>	3580 x 1425 <b>11'9" x 4'8"</b>	1135 <b>3'9"</b>	500 <b>1'8"</b>	770 <b>2'6"</b>	2500 <b>5,510</b>	44.9/0.46/ <b>6.51</b>
<b>D65WX-16</b> Power Angle Tilt Dozer	5790 <b>19'0"</b>	4.42 <b>5.78</b>	4010 x 1235 <b>13'2" x 4'1"</b>	1170 <b>3'10"</b>	695 <b>2'3"</b>	520 <b>1'8"</b>	2990 <b>6,590</b>	48.2/0.49/ <b>7.00</b>

\*Ground pressure shows tractor, ROPS cab, operator, standard equipment and applicable blade (EX, WX, PAT with counterweight).

## DIMENSIONS

	D65EX-16 SIGMADOZER	D65PX-16 Straight Tilt Dozer	D65WX-16 SIGMADOZER
A	5490 mm 18'0"	5680 mm 18'8"	5500 mm 18'1"
B	1880 mm 6'2"	2050 mm 6'9"	2050 mm 6'9"
C	3370 mm 11'1"*	3370 mm 11'1"*	3370 mm 11'1"*
D	3085 mm 10'1"	3085 mm 10'1"	3085 mm 10'1"
E	2970 mm 9'9"	3275 mm 10'9"	2970 mm 9'9"
F	560 mm 22"	915 mm 36"	760 mm 30"
G	65 mm 2.6"	65 mm 2.6"	65 mm 2.6"

\*3338 mm 10'11" is overall height if Komatsu sweeps are installed.

Ground clearance . . . . . 415 mm 1'4"

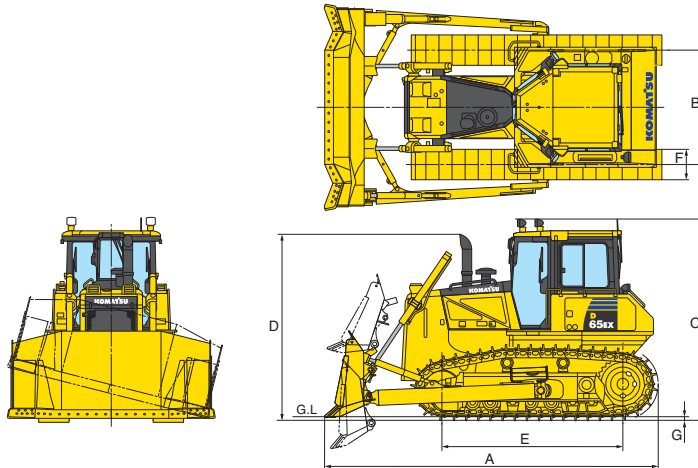

Shown with SIGMADOZER (D65EX-16) single grouser shoe.

for PAT Dozer

	D65EX-16 PAT Dozer	D65PX-16 PAT Dozer	D65WX-16 PAT Dozer
A	5790 mm 19'0"	5790 mm 19'0"	5790 mm 19'0"
B	2050 mm 6'9"	2230 mm 7'4"	2230 mm 7'4"
C	3370 mm 11'1"*	3370 mm 11'1"*	3370 mm 11'1"*
D	3085 mm 10'1"	3085 mm 10'1"	3085 mm 10'1"
E	2970 mm 9'9"	3275 mm 10'9"	2970 mm 9'9"
F	560 mm 22"	760 mm 30"	760 mm 30"
G	65 mm 2.6"	65 mm 2.6"	65 mm 2.6"
H	3545 mm 11'8"	3670 mm 12'0"	3670 mm 12'0"

\*3338 mm 10'11" is overall height if Komatsu sweeps are installed.

Ground clearance . . . . . 415 mm 1'4"

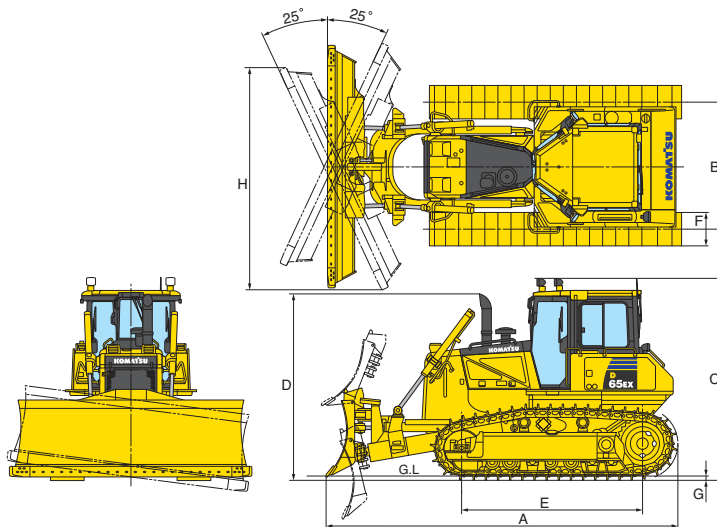

Shown with Power Angle Tilt dozer (D65EX-16) single grouser shoe.

## OPERATING WEIGHT

Tractor weight:

Including ROPS cab, rated capacity of lubricant, hydraulic control unit, coolant, full fuel tank, operator, and standard equipment.

D65EX-16 . . . . .	17560 kg	<b>38,720 lb</b>
D65PX-16 . . . . .	19210 kg	<b>42,350 lb</b>
D65WX-16 . . . . .	18170 kg	<b>40,060 lb</b>

for PAT dozer (EX, WX with rear counterweight)

D65EX-16 . . . . .	18340 kg	<b>40,430 lb</b>
D65PX-16 . . . . .	19210 kg	<b>42,350 lb</b>
D65WX-16 . . . . .	19210 kg	<b>42,350 lb</b>

Operating weight:

Including SIGMADOZER (EX/WX) or straight tilt dozer (PX) or Power Angle Tilt dozer, ROPS cab, operator, standard equipment, rated capacity of lubricant, hydraulic control unit, coolant, and full fuel tank.

D65EX-16 . . . . .	19950 kg	<b>43,980 lb</b>
D65PX-16 . . . . .	21310 kg	<b>46,980 lb</b>
D65WX-16 . . . . .	20670 kg	<b>45,570 lb</b>

for PAT dozer (EX, WX with rear counterweight)

D65EX-16 . . . . .	21300 kg	<b>46,960 lb</b>
D65PX-16 . . . . .	22200 kg	<b>48,940 lb</b>
D65WX-16 . . . . .	22200 kg	<b>48,940 lb</b>



## STANDARD EQUIPMENT FOR BASE MACHINE\*

- Air cleaner, double element with dust indicator
- Alternator, 60 ampere/24V
- Backup alarm
- Batteries, 200 Ah/2 x 12V
- Blade lift cylinders
- Color monitor, LCD
- Decelerator pedal
- Engine hood
- Engine intake centrifugal precleaner
- Engine, gull-wing side covers
- Fenders
- Front pull hook
- High mount foot rests
- Horn, warning
- Hydraulic driven radiator cooling fan with clean mode
- Hydraulics for rear equipment
- KOMTRAX Level 3
- Locks, filler caps and covers
- Muffler with curved exhaust pipe
- Oil pressure check ports for power train
- PM service connector
- Radiator mask, heavy-duty, hinged, perforated

- Radiator reserve tank
- Rear cover
- Seat, air suspension, fabric, headrest, low back, rotates 15° to right
- Seat belt, 76 mm 3", retractable
- Sealed electrical connectors
- Starting motor, 11.0 kW/24V
- Steering system:
  - Hydrostatic Steering System (HSS)
- Torque converter with auto lock-up
- Track roller guards, center and end sections
- Track shoe assembly
  - Heavy-Duty lubricated rotary bushing (PLUS) track
  - 560 mm 22" single grouser shoe (EX)
  - 760 mm 30" single grouser shoe (WX)
  - 760 mm 30" single grouser shoe (PX, WX with PAT)
  - 915 mm 36" single grouser shoe (PX)
- Transmission with auto/manual shift modes

- Underguards, heavy duty
  - Hinged engine oil pan
  - Transmission
- Water separator
- Wide core cooling package
- ROPS cab\*\*
  - Air conditioner
  - Air-conditioner intake precleaner
  - Cab accessories
    - 12V power supply
    - Cup holder
    - Rearview mirror
    - Sun visor
    - AM/FM Radio
    - Lunch box holder
  - Work lights
    - 2 front, hood mounted
    - 2 front, cab mounted
    - 1 rear, left fender mounted
    - 2 rear, cab mounted

\* Dozer assembly and rear mounted equipment are not included in base machine standard equipment.

\*\* Cab meets OSHA/MSHA ROPS and FOPS Level 2 standards.



## OPTIONAL EQUIPMENT

- Alternator, 90 ampere/24V
- Dozer assembly
- Drawbar, long type
- Hitch
- Rear counterweight 650 kg 1,430 lb
- Sanitary Landfill Package
- Shoes with circular relief hole
- Shovel holder (rear tank mounted)

- Straight tilt frame for use with allied blades
- Track roller guard, full length

### Multi-shank ripper (for D65EX/WX)

||Weight . . . . . 1770 kg 3,900 lb  
 Beam length . . . . . 2170 mm 7'1"  
 Maximum lift above ground . . . 640 mm 2'1"  
 Maximum digging depth . . . . 590 mm 1'11"



## ALLIED MANUFACTURER'S ATTACHMENTS (SHIPPED LOOSE)

- Guarding - Medford
  - Front sweeps (open top) 126 kg 300 lb
  - Front sweeps (w/ top cover plate) 204 kg 450 lb
  - Hinged cab side screens 54 kg 120 lb
  - Hinged cab rear screen 73 kg 160 lb
  - Tank guards 431 kg 950 lb
- Hydraulic winch - Allied H6H 1325 kg 2,900 lb
- Mechanical angle blade - Rockland 1100 kg 2,425 lb
- Topcon® Plug-N-Play
- Trimble® Ready

### SHOES

Models	Shoe	Additional weight	Ground contact area	Additional ground pressure to tractor
D65EX	510 mm 20" single-grouser shoe	-130 kg -290 lb	30395 cm <sup>2</sup> 4,711 in <sup>2</sup>	+4.7 kPa +0.05 kg/cm <sup>2</sup> +0.68 psi
D65EX	610 mm 24" single-grouser shoe	+260 kg +570 lb	36235 cm <sup>2</sup> 5,616 in <sup>2</sup>	-8.5 kPa -0.09 kg/cm <sup>2</sup> -1.24 psi
D65WX	660 mm 26" single-grouser shoe	+390 kg +860 lb	39205 cm <sup>2</sup> 6,077 in <sup>2</sup>	-11.8 kPa -0.12 kg/cm <sup>2</sup> -1.72 psi

AESS797-01

©2010 Komatsu America Corp.

Printed in USA

D06(5M)OSP

06/10 (EV-1)

